



This handout is only applicable to residential detached garages on single-family lots. A permit is required for all garages regardless of size.

Contractors and Homeowners as General Contractors:

- Homeowners may obtain the building permit for a detached garage or accessory building on their own single-family lot if they perform the work themselves and if it is their primary residence.
- Any person hired to perform work must have the required registration to do work within the City of Lakewood. Registration may be obtained through eTRAKiT.
- Mechanical, electrical, and plumbing systems work may be performed by MEP systems contractors registered with the City of Lakewood. After a permit has been issued, the "add contractor to existing permit" form must be filled out at <https://www.lakewood.org/Government/Departments/Public-Works/Building-and-Construction-Permits>. Homeowners who wish to do the mechanical, electrical, and plumbing work on their own projects must add themselves into the permit using the add contractor to existing permit button and the link above for each of the building systems they will be working on.

Submittal Requirements:

- Provide a completed permit application through eTRAKiT.
- Your project must comply with the required setbacks for your lot and structure location. Please check with the Planner-of-the-Day at 303-987-7571 or e-mail at POD@lakewood.org to verify your proposed structure meets all setback and location requirements.
- Upload a completed permit application along with a complete set of the following plans:
 1. Plot Plan drawn to 1" = 30' or larger standard scale
 - See page 2 for an example plot plan.
 - You may use an Improvement Location Certificate (ILC) to complete the plan. Use the same scale as the ILC to add the required information.
 - Include north arrow and scale used.
 - Provide the property address and names of all adjacent streets
 - Show all property lines and easements with dimensions to the new garage.
 - Show footprint of existing home and new detached garage. Provide dimensions from the new garage to the existing residence or primary structure on the property.
 - Show all existing accessory buildings and label type and dimensions (e.g., 10' x 12' shed).
 - Show all walks, drives and patios.
 - Provide dimensions on all sides from the new detached garage to property lines and to any other structures on the lot.
 2. Floor plan drawn to ¼" = 1' or larger standard scale.



Residential Detached Garage

- See page 3 for an example detached garage floor plan. Provide all the information as shown on the example.
- Show dimensions of detached garage.
- Include location, width and height of all doors and windows. Indicate the header size at each door or window opening.
- Truss shop drawings that bear the seal and signature of a registered Colorado P.E. must be provided when factory-built trusses are being used rather than rafter systems.
- Indicate if the garage is to be heated, plumbed, or wired in any manner. Include schematic drawings of any gas lines or plumbing if applicable. Indicate the location of lights, switches and outlets, and the power source from the primary electrical panel. If a sub-panel is being installed in the new garage, provide a single line electrical diagram showing the size wiring and conduit, grounds etc. used to provide power to the new sub-panel.
- Heated detached garages must be insulated to meet the requirements of the International Energy Conservation Code. Indicate window and door U-values, and list R-values of insulation at walls, ceiling, and slab/foundation.
- Garage Building Section: See page 4 for an example garage building section. Provide all the required information as shown on the example garage section.
- Indicate on the building section drawing the type and size of foundation you will use. See page 3 for example foundation details.
- Monolithic slab foundations are restricted to unheated buildings of light frame construction and a maximum of 600 square feet and 10-foot wall height.
- Specify the roof slope and roof covering product you are using. Refer to the Roofing/re-roofing handout for more information.
- Service panel or subpanel circuit directory shall identify the overcurrent protective device space(s) reserved for future electrical vehicle charging as "EV CAPABLE."
- A soils report is required for all detached garages over 600 square feet or that are located closer than 10 feet to the primary structure on the site.

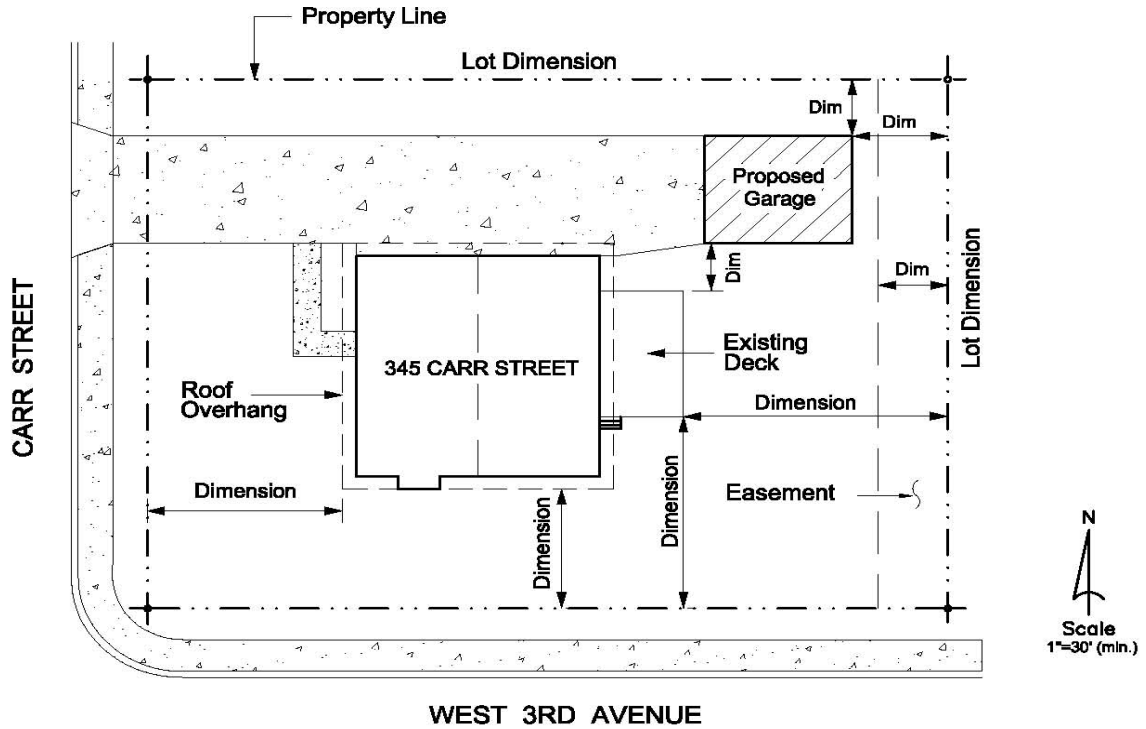

WEST 3RD AVENUE
SAMPLE PLOT PLAN

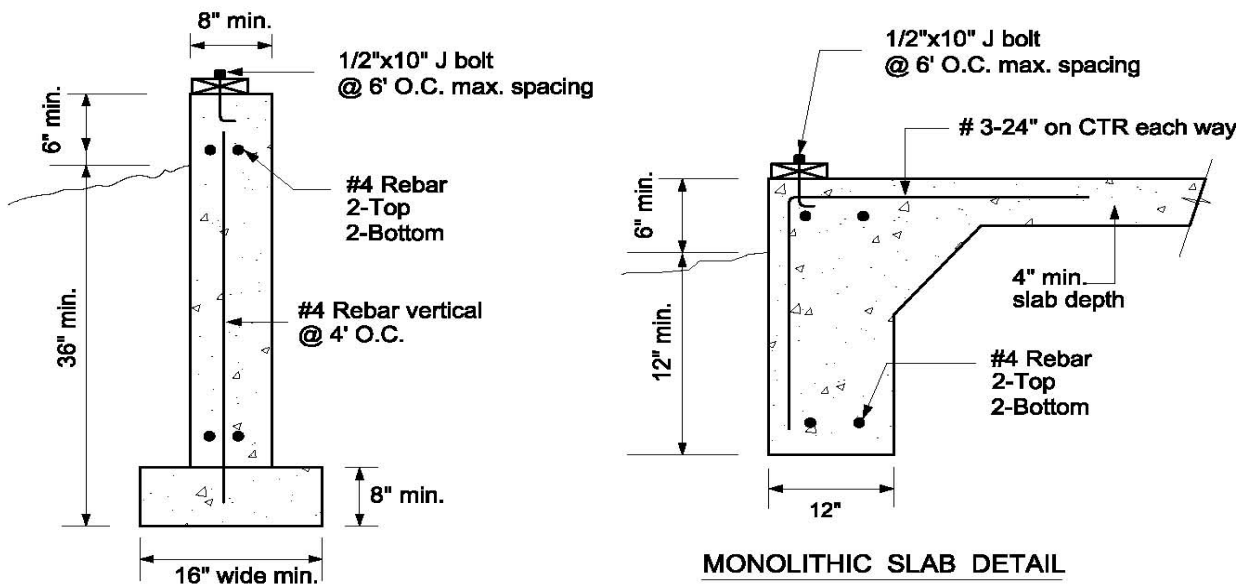

SAMPLE FOUNDATION DETAILS



Example of Garage Section Drawing

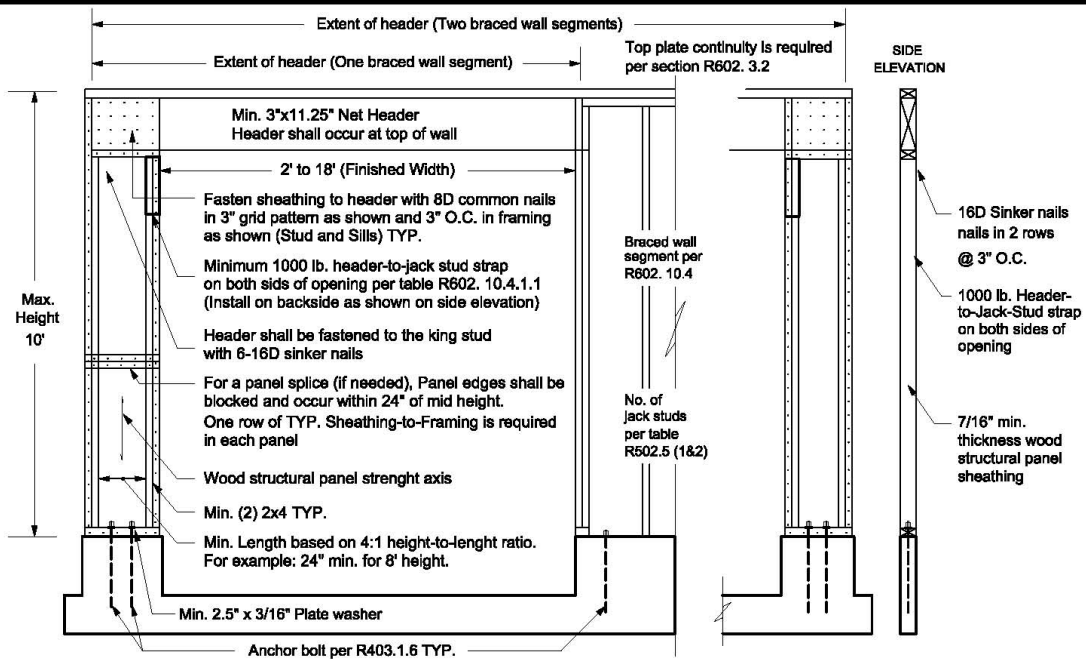
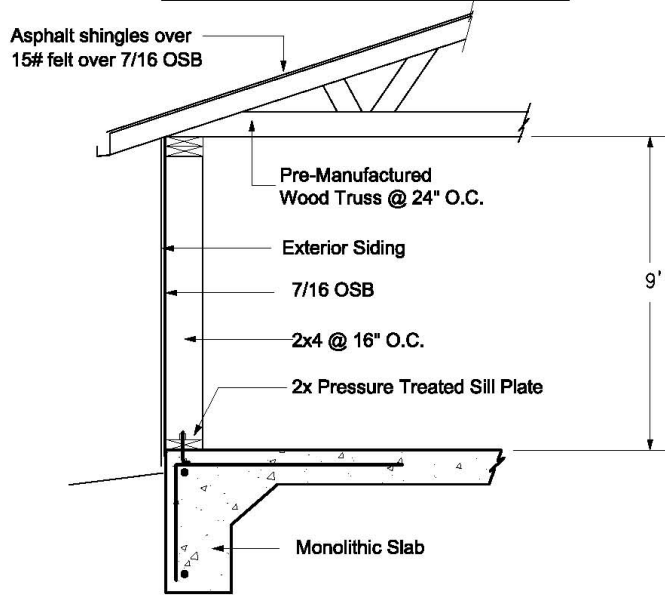

For S1: 1 inch = 25.4 mm. 1 foot = 304.8 mm. 1 pond force = 4.448 N.



Example of Garage Floor Plan

